

FLAT HANDLE UNIT 9626 SERVO

Production of bags with flat handle for TRIUMPH block bottom bag machine



FLAT HANDLE UNIT 9626 SERVO

Production of bags with flat handle for TRIUMPH block bottom bag machine

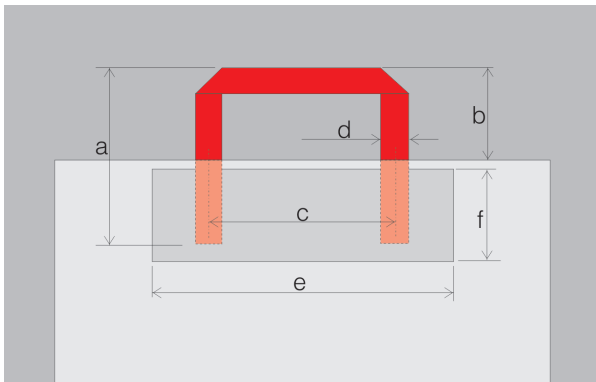
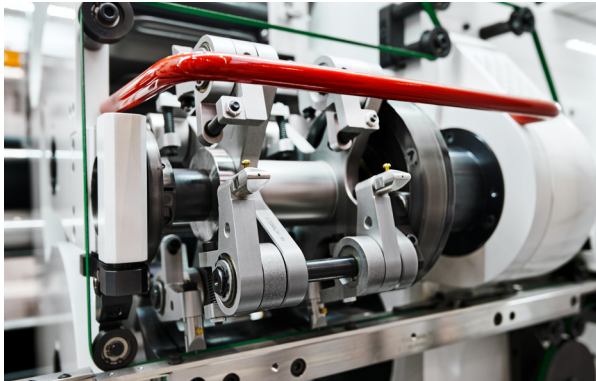

Technical data

Handle system height*	Position a	max. 175 mm	up to 6.89 inch	
Handle excess*	Position b	max. 95 mm	up to 3.74 inch	
Handle width	Position c	110 mm	4.33 inch	
Handle tape width	Position d	18 mm	0.71 inch	15 mm 0.59 inch
Handle tape length		350 / 450 mm	13.78 / 17.72 inch	
		Standard: 350 mm	Standard: 13.78 inch	
Handle paper	3-layer folded	100–140 g/m ²	100–140 g/m ²	
	5-layer folded	70–90 g/m ²	70–90 g/m ²	
Handle paper width	3-layer folded	45 mm	1.77 inch	40 mm 1.57 inch
	5-layer folded	80 mm	3.15 inch	75 mm 2.95 inch
Reinforcement patch width	Position e	160/170/180 mm	6.29/6.69/7.09 inch	
Reinforcement patch length	Position f	50/60/70/80 mm	1.96/2.36/2.76/3.15 inch	
Reinforcement patch paper			70–120 g/m ²	

* depending on handle cut off length

Innovations

- Control the entire machine line via additional touch panel at the handle unit
- Continuous servo technology
- Settings on the machine can be altered during production
- Extremely short change over times

Optional equipment

- Laminating unit for 2 layer bags

Format range SM (flat handle)

Bag width	180–460 mm (540 mm)	7.09–18.11 inch (21.26 inch)
Cut-off length	240–770 mm	9.45–30.31 inch
Paper width	max. 1500 mm	max. 59.06 inch
Max. distance handle center – handle center	750 mm	29.52 inch
Min. distance handle center – handle center	250 mm	9.84 inch

Garant Maschinenhandel GmbH

Gewerbepark Antrup 17 · 49525 Lengerich · Germany · Phone: +49 5481 809-0 · Fax: +49 5481 809-8109
 info@garant-maschinen.de · www.garant-maschinen.de



GARANT MASCHINEN

MEMBER OF W&H-GROUP