

FLAT HANDLE UNIT SM/SERVO

Production of bags with flat handle for TRIUMPH block bottom bag machine

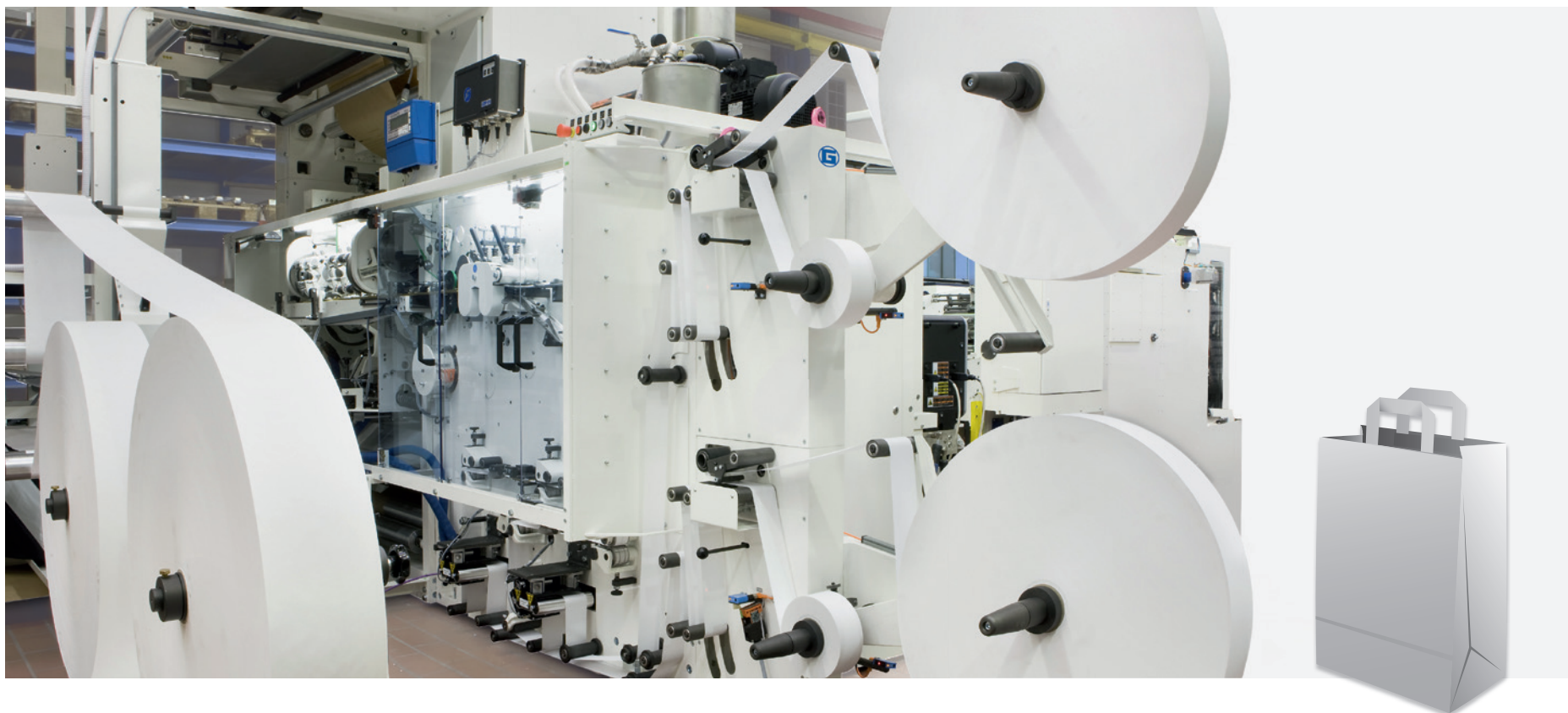

FLAT HANDLE UNIT SM/SERVO

Production of bags with flat handle for TRIUMPH block bottom bag machine

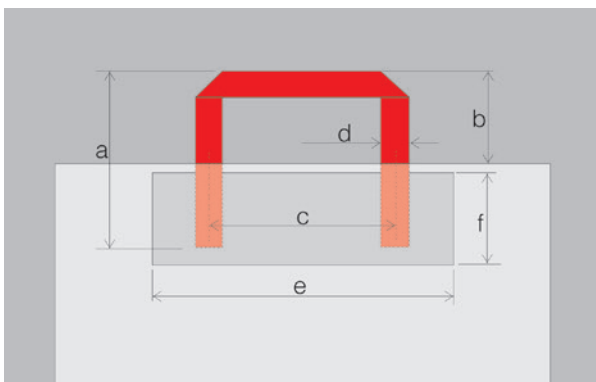

Technical data

Handle system height	Position a	up to 175 mm*	up to 6.89 inch*
Handle excess	Position b	up to 95 mm*	up to 3.74 inch
Handle width	Position c	110 mm	4.33 inch
Handle tape width	Position d	18 mm	0.71 inch
Handle tape length		350–450 mm	13.78–17.72 inch
		Standard 350 mm	Standard 13.78 inch
Handle paper	Kraft paper	3-layer folded	100–140 g/m ²
		5-layer folded	70–90 g/m ²
Handle paper width		45 and 80 mm	1.77 and 3.15 inch
Reinforcement patch width	Position e	180 mm	7.09 inch
Reinforcement patch length	Position f	70 mm	2.76 inch
Reinforcement patch paper	Kraft paper		70–120 g/m ²

* depending on handle cut off length

Innovations

- Continuous servo technology
- Settings on the machine can be altered during production
- Extremely short change over time

Optional equipment

- Laminating unit for 2 layer bags

Format range SK (loop handle)

Bag width	180–460/540 mm	7.09–18.11/21.26 inch
Cut-off length	270–770 mm	10.63–30.31 inch
Paper width	max. 1320/1500 mm	max. 51.97/59.06 inch
Max. distance handle center – handle center	670 mm	26.38 inch
Min. distance handle center – handle center	250 mm	9.84 inch

Garant Maschinenhandel GmbH

Gewerbepark Antrup 17 · 49525 Lengerich · Germany · Phone: +49 5481 809-0 · Fax: +49 5481 809-8109
 info@garant-maschinen.de · www.garant-maschinen.de